

参考数据

Reference data

载流能力

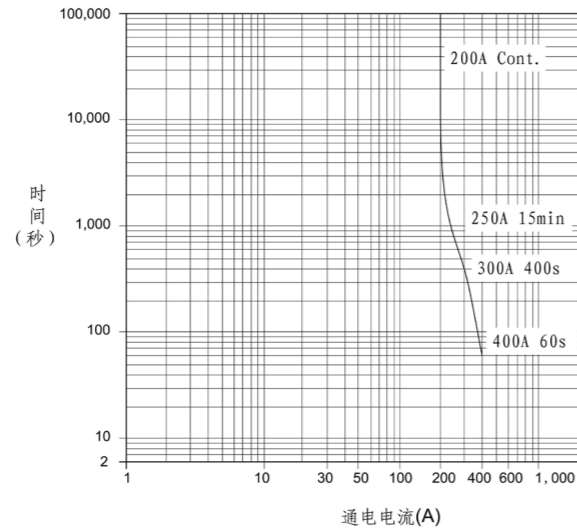

Graph 1

外形尺寸

Dimension

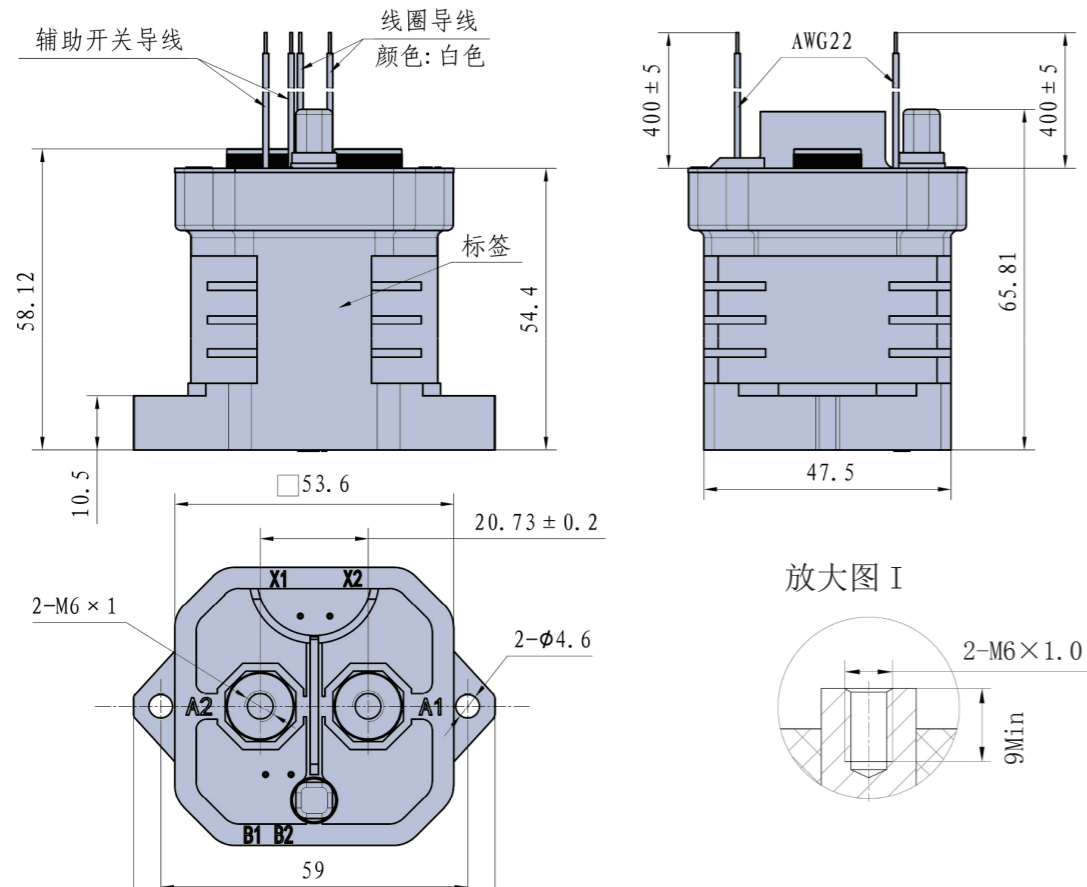

备注	Note	
尺寸单位	mm	Unit
视角		Visual angle
未标注尺寸公差	< 10 : ±0.3	Tolerance not specified
	10 ~ 50 : ±0.6	
	> 50 : ±1.0	
线圈导线长度与接插件可以定制	Coil wire length and connector could be customized	

接线示意图 Schematic

E 型
(负载无极性)

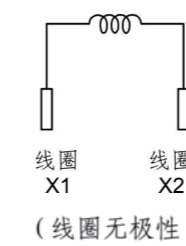
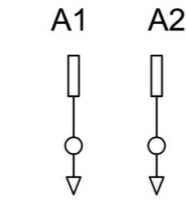

E Type

Coil and main contacts are non-polarized.

G 型

(负载无极性)

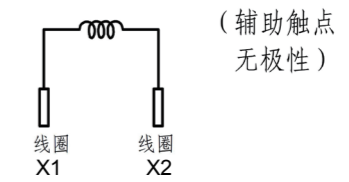
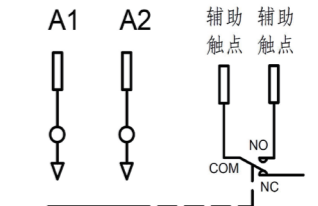

(线圈与辅助触点无极性)

G Type

main contacts and auxiliary contacts are non-polarized.

Coil is non-polarized.

扭矩范围	Torque range	
紧固件规格	M6×12 (配套提供 Provided)	Thread size
主触点接线柱	4.5-6.5N·m	Main contacts
接触器底座	1.8-2.5N·m	Mounting bottom

环境性能	Environmental Characteristics	
冲击	10g peak, 11ms 1/2 sine (线圈通电 coil energized)	Shock
振动	10g peak, 80~2000Hz sine	Vibration
使用与贮存环境温度	-40°C - +85°C	Temperature range
使用与贮存环境湿度	5% - 95%RH (无结露、结冰 No condensation and freezing)	Humidity range

注意事项

1. 凡安装接触器时均要使用防松垫圈以防止螺纹紧固件松脱。拧紧紧固件的扭力范围应在规定的范围内，超出扭力最大值可能会导致产品破裂。
2. 本接触器的触点有无极性和有极性两种，在连接接触器时应按产品端盖上的极性标示（+A1,-A2）进行接线。接线错误时，可能会引发意外的误动作、异常发热，因此敬请注意。
3. 在超过线圈额定值、触点额定值、寿命等规格范围使用的情况下，可能会引起异常发热，因此敬请注意。
4. 不要使用跌落过的产品。
5. 避免把产品安装在强磁场的地方（靠近变压器或磁铁处），或靠近有热辐射的物体。
6. 相邻安装多个接触器时，请注意热量相互干扰所引起的异常发热，以及接触器外部的端子间的绝缘距离。
7. 电寿命
本接触器为高压直流开关，在其最终的击穿模式中，它可能会失去应有的切断功能，因此不要在超过它的切换能力和寿命参数的状态下使用（请将该接触器当作一个有规定寿命的产品来对待，必要时作替换）。接触器一旦失去断开切断能力，则有可能引起其周围零件燃烧，所以要设计好保护线路，确保电源可在 1 秒种内被切断。
8. 内部气体的扩散寿命
本接触器采用密封仓触点，仓内充有气体，气体的扩散寿命由触点仓内的温度（即环境温度+触点通电产生的温升）所决定，因此应确保环境温度为 -40 至 +85°C。
9. 如果接触器的线圈和触点连续通以额定电压（或电流），电源被切断后又马上接通，此时由于线圈的温度增加，线圈的电阻会增大，从而使得产品的吸合电压升高，有可能导致超出额定吸合电压与释放电压，在这种情况下，应采取以下措施：如降低负载电流，限制持续通电时间或采用比额定吸合电压高的线圈电压。
10. 主触点的额定参数适用阻性负载，如果采用感性负载（L 负载）同时 $L/R > 1\text{ms}$ 时，应为该感性负载并联一个浪涌电流吸收装置，如未采取措施，可能会造成接触器电气寿命缩短、切断不良。
11. 产品线圈的驱动电路功率必须大于产品线圈功率，否则会降低产品的切断能力。
12. 请务必切断电源后再进行接线。
13. 在无负载的情况下开闭时，接触电阻可能会上升，因此敬请注意。
14. 要小心不要让杂物和油污沾到主引出端上，且外接端子应与产品的主引出端可靠接触，否则有可能会造成引出端异常发热。
15. 使用电容负载（C 负载）时，请对电容负载采取预充电等措施，使冲击电流控制在接触器的额定电流以下，如未采取措施，可能会造成触点粘连。

Notes

1. Please use the washer to prevent loosening when contact installation. Screw locking torque should in specified range, damage may occur when it is beyond.
2. The contactor have two types of contacts, polarity and non-polarity, there is +A1 and -A2 marks on cap of product. Please follow the wiring graph to connect the wire (for current flows from +A1 to -A2), wrong connection may cause malfunction or abnormal heating.
3. Please note that could be abnormal fever when using condition is beyond the specified rating value like coil rated, contacts rated and life and so on.
4. Please do not use the product when it has fallen down.
5. Please avoid installation in strong magnetic field (around the transformers or the magnets) and the heating objects nearby.
6. When installing multiple contactors adjacent to each other, please pay attention to the abnormal heating caused by heat interference and the insulation distance between the terminals outside the contactor.
7. Life time of the electricity
The contactor is high voltage DC switch, it will lose the breaking function during its final shocking module, therefore, it cannot be used by exceeding its breaking capacity and life-time parameter (please consider the contactor as the limited life-time product and change it when necessary). The surrounding components may burnt while the contactor lose its breaking function. So, it is very important to design and protect the circuit properly and make sure the power can be cut within 1 second.
8. The spreading life-time of the inner gas.
The contactor adopts the sealed cabinet contacting point, there is gas inside of the cabinet, the gas life-time is decided by the temperature inside of the contacting room (environmental temperature + temperature produced by power setup on contacting point), therefore, the environmental temperature should be kept between -40 till +85°C .
9. The coil resistance will be increased due to the coil temperature goes up if the rated voltage (or current) setup continuously on the coil and the contacting point, thus, the operating and breaking voltage of the product go up, and the rated voltage may be exceeded or released. Under this condition, the following measurements can be taken: decrease the loading current and limit the continuous power setup time or, adopts the coil voltage higher than the rated ones.
10. The rating load of contact is resistive load. Please assure the surge absorption device together with inductive load when using the $L/R \geq 1\text{ms}$ inductive load (L Load), otherwise it may lead to the decrease of electrical life and defective switch.
11. Drive power must more than coil power, or it will make product's break ability weaker.
12. Do wiring should be after power-off.
13. Contact resistance may rise when product switching with no load.
14. Please avoid grease or other foreign matter on the terminal, and make sure conductors are reliable contact with product's main terminals, otherwise, abnormal heating may occur at terminals.
15. When using capacitive load, it is need a pre-charge circuit to assure the impulse current less than contact's rating current, otherwise, it may cause main contacts welding.